



ETGplus
Tool Grinding Machines

ETGplus



The choice for tool reconditioning

The ETGplus, with its single-ended, direct-drive 10 HP grinding spindle (with automatic HSK) minimizes the moment-of-error by positioning the abrasives on the centerline of the B-axis pivot. This feature allows the ETGplus to meet the most accurate of cutting tool specifications. The ETGplus automatically probes the wheel pack for diameter and linear position.

The ETGplus is available with powerful, flexible and easy-to-use NUMROTOplus® software packages with standard 2D simulation and DXF form capability. Star can provide the optional NUMROTO-3D software package for 3D simulation and machine collision protection

For flexible, fast, automatic loading, Star can equip the ETGplus with automated systems.

The ETGplus is a five-axis CNC featuring the most up-to-date software in the industry for the ultimate in flexibility: grinding end mills, step drills, reamers, form cutters, gun drills, burrs, and shaper cutters. Star also provides programming for special orthopedic surgical tools and instrumentation.

Online preventative maintenance schedules and on-screen diagnostics ensure machine maintainability and reliability. A central modularized compartment for pneumatic and lubrication components allows for fast and worry-free part replacement.

Throughout the world, our customers can expect and receive support and service at its best, including ongoing software updates. We not only sell productivity—we support it.



ETGplus with NUMROTOplus® software

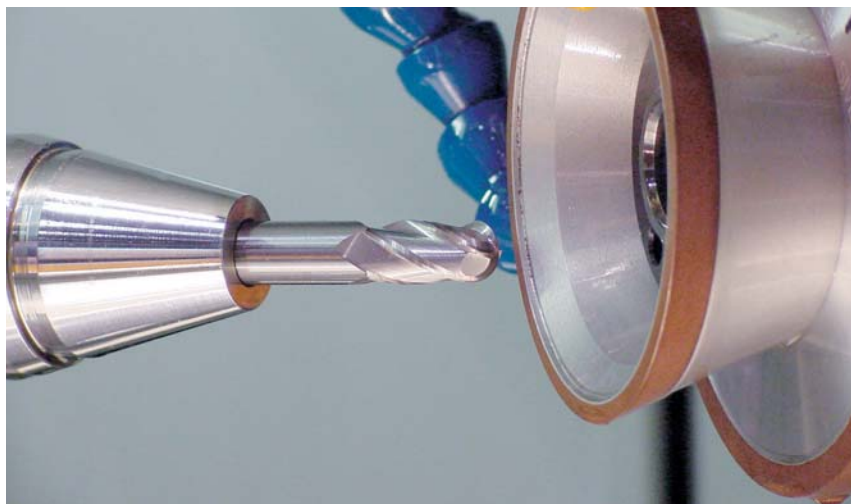

ETGplus grinding a ball nose end mill



The ETGplus allows you to grind a wide variety of tools

ETGplus features:

- Five-axis, NUM CNC control.
- NUMROTOplus® operator interface running on a Windows operating system with flat screen monitor.
- NUMROTOplus® 2D or add the optional NUMROTO-3D grinding simulation.
- Dynamically stiff machine with digital servo motors, ultra-precision headstock.
- Heidenhain glass scales on linear axes.
- CNC high-speed servo positioning and linear rail system for accurate axis positioning on precision-ground ball screws.
- Automatic part probing system.
- Wheel probing system to precisely measure the grinding wheels' sizes and locations, eliminating the need for time-consuming measurements each time wheels are changed.
- A wide selection of optional coolant delivery and filtration systems with mist collection.
- HSK quick release grinding wheel pack allows wheel pack changes in under one minute while providing the necessary locating repeatability for off-line wheel dressing.
- HSK quick-release precision hydraulic chucks with sleeve available for precision chucking of tools from 1/8 to 1-1/4 inch diameter range.
- Cat 50 collet chuck and collet set available for chucking tools from 1/8 to 1 inch diameter range.
- Capability of sharpening extended-length tools such as gun drills and gun reamers by moveable direct-drive headstock for tools up to 21 inch overall length.
- Direct drive head stock with up to 1000 rpm for cylindrical grinding of a wide range of diameters while maintaining 350 inch pounds of torque for the quick and accurate fluting of large diameter solid carbide tools.



ETGplus operator station

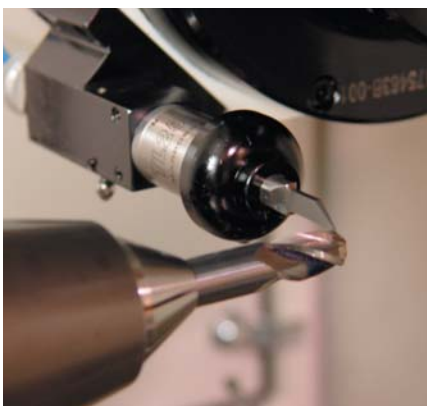



Automatic grinding wheel probing system for ETGplus only



Between-center tooling to grind longer tools on the ETGplus

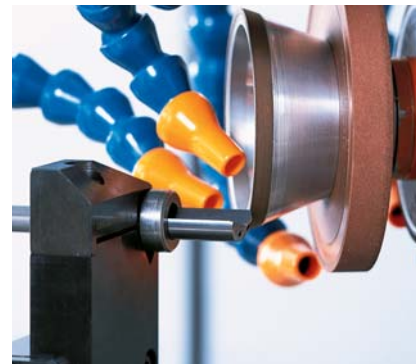

Grind tools up to 21 inches overall length on the ETGplus using the bushing plate.

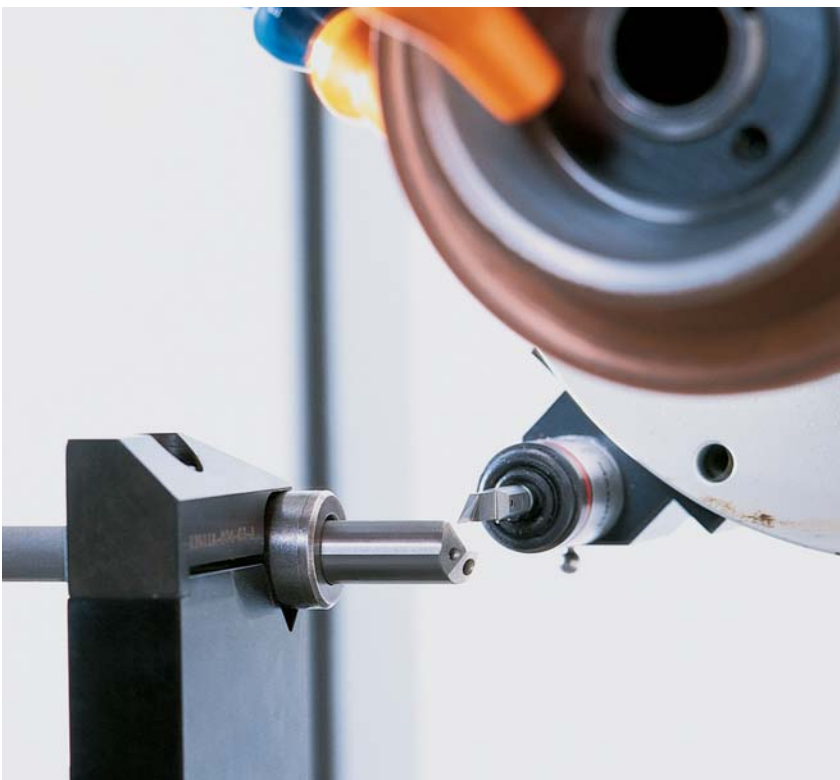

Part probing on the ETGplus



The ETGplus features a movable direct-drive headstock



Precision grinding of burr tools on the ETGplus

Technical Data

ETGplus machine capacity		
Maximum workpiece diameter	100	mm
Maximum workpiece length	200 (530)	mm
A - axis workhead spindle rotation	40 (1000)	RPM
B - axis grinding spindle swivel	16	RPM
X - radial travel work spindle slide	300	mm
Y - vertical travel tool head slide	220	mm
Z - axial travel tool spindle column slide	350	mm
Grinding spindle	30 Kw	40 HP
Maximum grinding spindle speed	10,000	RPM
Maximum grinding wheel diameter	150	mm
Smallest programmable movement: linear	.0001	mm
Linear axis glass scale feedback resolution	.00001	mm
Smallest programmable movement: rotary	.0001	degrees
Rotary axis feedback resolution: A-axis	.0000001	degrees
Rotary axis feedback resolution: B-axis	.0000005	degrees
Main dimensions, base machine (l x w x h)	2,38 x 1,93 x 2,33	Meters
Total weight, base machine	3,600	kg

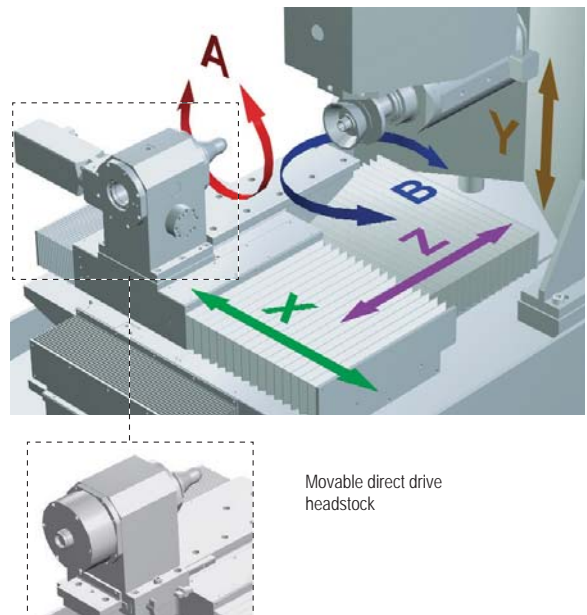
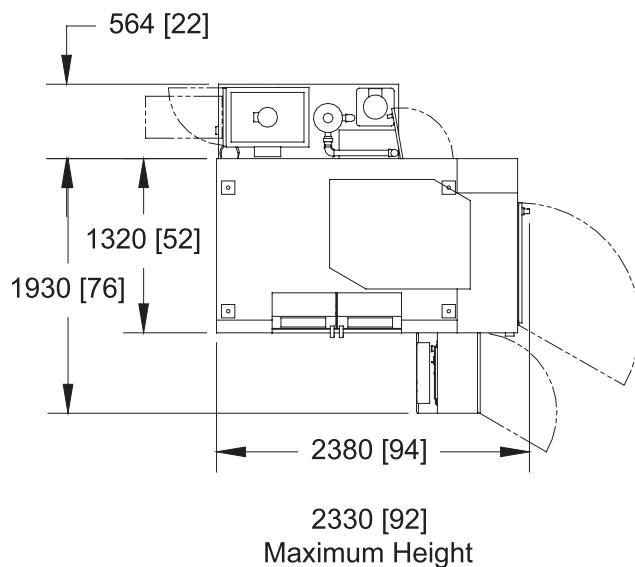

NUMROTOplus® Software

NUMROTOplus® makes it easy for operators to grind parts:

- Sequentially walks the operator through the graphical interface during the tool description process.
- Generates a custom grind program for each tool.
- Shows tool geometry using a 2D scale representation of the tool.
- Provides immediate feedback as the operator enters each dimension.
- Simulates grinding to show cross-sectional details.
- Based on the selected feed rates and the tool dimensions, the software automatically calculates a grinding time for each operation and a total cycle time for the part.
- Minimizes wheel changes and boosts machine productivity by letting the operator use wheels for multiple operations.
- For even more flexibility, order the optional NUMROTO-3D visualization software package.

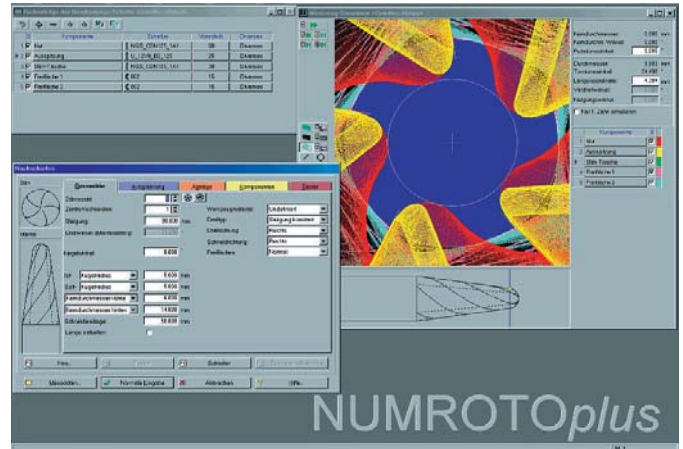

Standard NUMROTOplus 2D Software

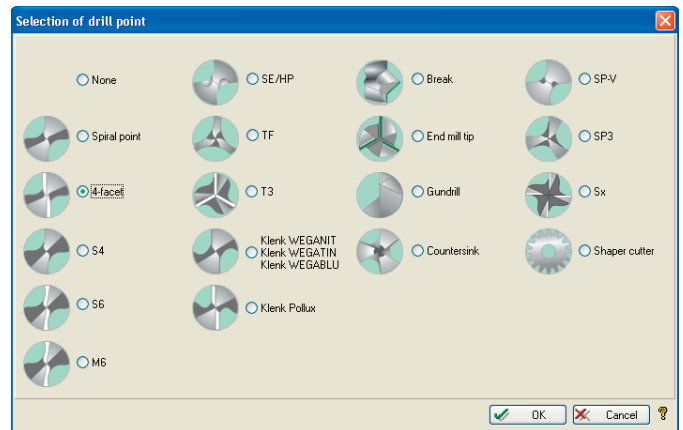

Menus walk the operator through the programming process.

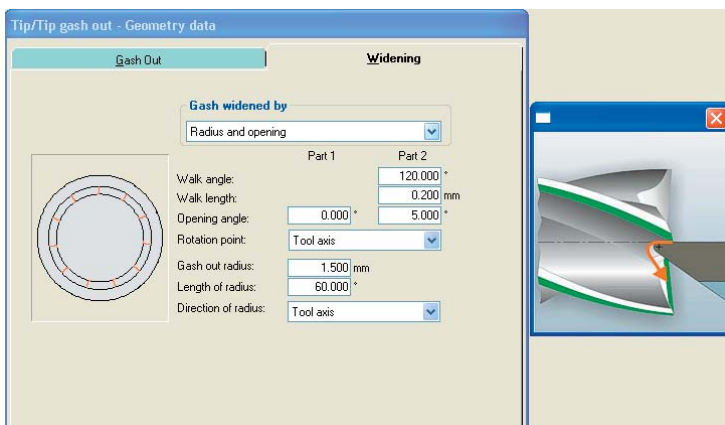

Detailed graphics illustrate the context for each parameter adjustment.



Technology

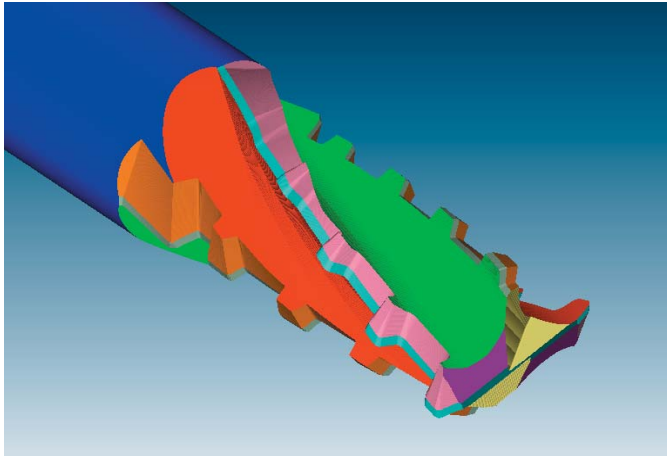

Optional NUMROTO-3D visualization Software

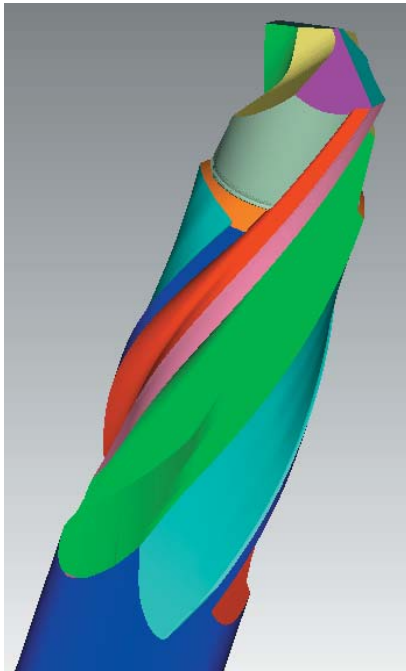

NUMROTO-3D software works for any tool from the exotic to the ordinary

NUMROTO-3D® Software

Cutting tools are made in three dimensions and 3D simulation software helps operators understand the grinding process. Using NUMROTO-3D, you can maximize the power of the computer and minimize scrap. With NUMROTO-3D and accurate scale representations, you can see the tool before you grind it.

The optional NUMROTO-3D simulation package works hand in hand with NUMROTOplus® to provide the operator with a virtual representation of the tool before the operator ever puts the work piece in the machine. The operator can test the program, view, measure the virtual part, and even tell whether or not there are collision problems with other wheels. When the operator is satisfied with the virtual part, it is a simple matter to upload the grind program to the machine and start the grinding cycle.

Go ahead, experiment, create, watch the tool being ground, and refine your prototypes without scrapping a single blank. What you see on the screen is what you'll get when you grind the tool. You can even preview the tool from any angle.

To run NUMROTO and NUMROTO-3D, Star supplies a personal computer with plenty of power for running 3D simulations and a flat panel monitor as the operator interface. Naturally, it allows for quick and inexpensive upgrades as new technology becomes available.



NUMROTO does all these tools and a lot more.

CNC Power Engineering

Hardware – Software – Brainware

NUM 
CNC HighEnd Applications

System technology from one source

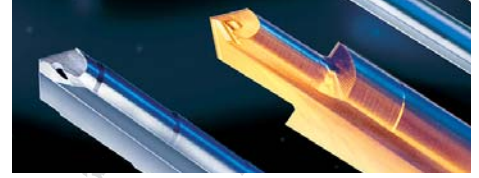

CNC Hob Sharpening Machines
CNC Shaper Cutter Sharpening Machines
CNC Broach Grinding Machines
CNC Universal Tool Grinding Machines
CNC Spline Grinding Machine

Gear Cutting Tools
Form Relieved Milling Cutters
Saw Blade Cutters
Rack Cutters
Multiple Thread Milling Cutters

Gun Drills
Solid Carbide Drills and Reamers
Pressure Coolant Drills and Reamers
"PCD" Drills and Reamers



Star Cutter Company
Elk Rapids Engineering
Machine Tool Technology
210 Industrial Park Drive
PO Box 728
Elk Rapids, MI 49629-0728
USA
Tel. +1 231 264 5661
Fax. +1 231 264 5663
e-mail sales@starcutter.com

Star Cutter Company
23461 Industrial Park Drive
PO Box 376
Farmington Hills, MI 48335-2855
USA
Tel. +1 248 474 8200
Fax. +1 248 474 9518
e-mail sales@starcutter.com



Star Cutter Company, Farmington Hills, Michigan, USA