



# PTG-1

## Star CNC Hob and Shaper Cutter Resharpener Center

HOB AND SHAPER CUTTER

### STANDARD MACHINE SPECIFICATIONS

The Star PTG-1 is a six (6) axis CNC controlled hob and gear shaper cutter sharpening and reconditioning machine for in-house maintenance of straight and spiral gash hobs, dish and helical gear shaper cutters and a wide range of round tools.

#### Technical Data - Capacities & Limits

Nominal Workpiece Diameter	200 mm
Maximum Workpiece Length	250 mm
A - axis Workhead Spindle Rotation	125 rpm
B - axis Grinding Spindle Swivel	16 rpm
X - axis Radial Travel Workspindle Slide	300 mm
Y - axis Workhead Spindle Rotation	125 rpm
Z - axis Workhead Spindle Rotation	125 rpm
Grinding Spindle Power (Peak)	30 kw
Maximum Grinding Spindle Speed	10000 rpm
Maximum Grinding Wheel Diameter	254 mm
Width (Approximate)	3440 mm
Height (Approximate)	2550 mm
Length (Approximate)	2880 mm
Weight (Approximate Net)	3900 kg

Actual machine W-H-L and Weight depend on ordered configuration. Technical data is subject to change without notice and may vary according to the options purchased with machine.

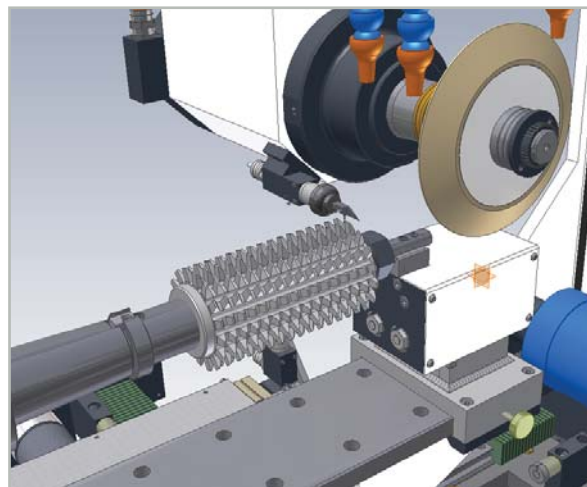

### WORKING RANGE KINEMATICS

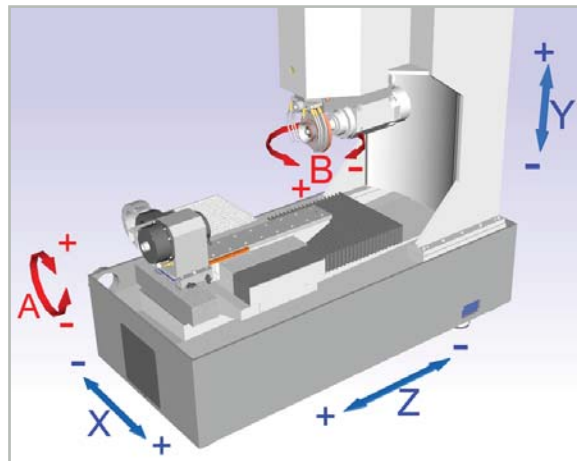

Technical data in quote supersedes published information.

# PTG-1

## Star CNC Hob and Shaper Cutter Resharpener Center

Standard Equipment	
Description	
Base machine with NUM Axiom 6 Axis CNC Control	
Wired for 460 volts, 3 phase, 60 Hz	
PC with Windows XP, flat screen, keyboard and mouse	
Basic NUMROTOplus Software	
CNC Operator Screen	
NUMROTO plus Part Probing Software	
NUMROTO plus Wheel Probing Software	
NUMROTO plus Software for Cylindrical Grind	
NUMROTO plus 2D Grinding Simulation	
Part Probing System	
Grinding Wheel Probing System	
Automatic HSK Wheel Pack Mounting	
Direct Drive A axis headstock	
Adjustable A axis headstock for tools up to 10" OAL, 8" dia.	
Cat 50 Headstock Spindle with 40 mm through hole	
Single end direct drive grinding spindle, 30 HP peak	
Zoned high pressure coolant delivery ready	
Closed loop chiller for grinding spindle and headstock	
Anti-backlash headstock with rotary glass scale positioning	
Machine painted one standard color	
<b>Standard Equipment Total (\$):</b>	

Optional Equipment	
Description	Price (\$)
NUMROTOplus software package for straight & spiral gash hobs	
NUMROTOplus software package wheel profile determination	
NUMROTOplus software package gear shaper cutters	
NUMROTOplus software package 3D machine simulation	
Tailstocks	
Solid hob arbors with spacers and nut	
Solid hob arbor setup fixture	
Manual hydraulic hob arbors with spacers and nut	
Manual hydraulic hob arbor setup fixture	
HSK quick change shaper cutter arbors	
HSK receivers for headstock driver	
Accessories tooling package	
Norton Wheel Dresser	
G II Wheel Dresser for superabrasives	
Dual canister coolant system with MistBuster	
FM200 fire suppression system	
CBN grinding wheels	
Extended warranty	
<b>Optional Equipment Total (\$):</b>	

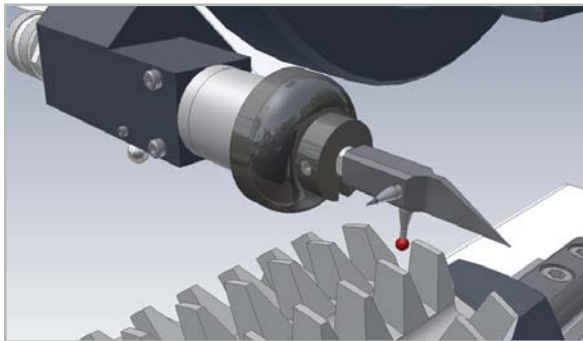

Total Cost:	
Standard Equipment Total (\$):	
Optional Equipment Total (\$):	
<b>TOTAL (\$):</b>	

Submit a  
**QUICK QUOTE** Request

