



PTG 6



Six Wheel Station
&
Coolant Line
Manifold Changer



Profitable solutions for manufacturing cutting tools

The Star PTG-6 is engineered to provide profitable solutions for the manufacturing of complex cutting tools. With NUMROTOplus® software and an automatic six-station grinding wheel and coolant line manifold changer, this machine exceeds industry expectations for accuracy, flexibility, reliability / maintainability, and stability.

Accuracy – The accuracy of the PTG-6 is highly predictable due to the integration of world-class machine components. A powerful, precision grinding spindle with HSK grinding wheel mounting locates the grinding wheel on the center of the B-axis pivot. The headstock is direct drive for ultimate positioning capability, variable RPM and low maintenance. All linear axes have Heidenhain glass scales that set the standard for machine tool accuracy.

Flexibility – NUMROTOplus® is a user-friendly, high-end application software package for producing a wide range of complex tools. The standard 2D simulation allows cross sectional visualization, while the optional 3D virtual grinding simulation with machine collision detection eliminates costly setup time. Innovative work holding and tool support options, programmable steady rests and tailstocks plus a variety of custom designed tooling enables the production of the highest quality precision cutting tools.

Reliability / Maintainability – The PTG-6 is designed and built to exacting processes that are unmatched in the industry. Air purge of scales, headstock, and grinding spindle eliminates any contaminants. Full disclosure of machine drawings, documentation, and a complete parts list is available on the machine's computer. Proven diagnostic systems for troubleshooting error messages and unlimited direct access / phone support are available for the operator.

Stability - The PTG-6 is engineered for both structural and thermal stability using some of the most advanced engineering tools available including 3D Solid Modeling and Finite Element Analysis (FEA). For dynamic stability, a dedicated closed loop chiller controls heat build-up within the grinding spindle and headstock.

The PTG-6 is designed, built, serviced and supported to maximize uptime, maximize throughput, and maximize PROFITS.

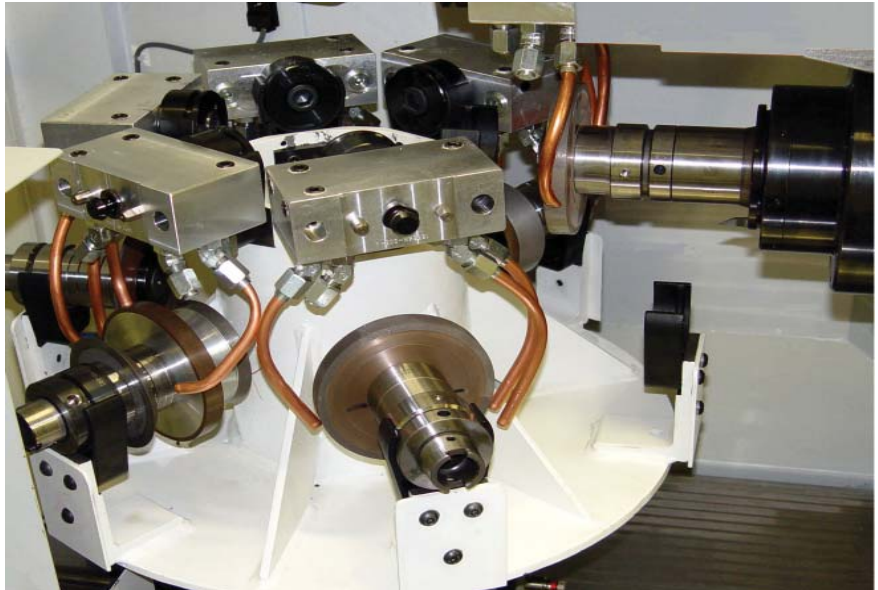

PTG-6 with grinding wheel pack and coolant manifold exchange system

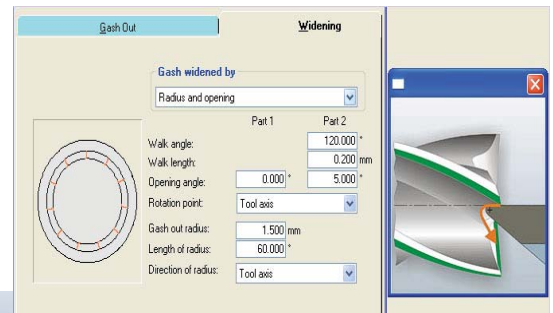

Detailed graphics illustrate the context for each parameter adjustment.

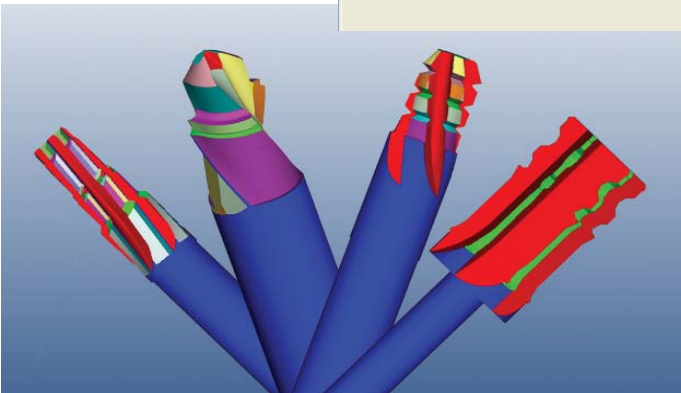

NUMROTO 3D software works for any standard tool to the most complex





Pivoting operator console



Part Probe on the Grinding Spindle



Automatic Grinding Wheel Probing



Auto HSK wheel pack mount

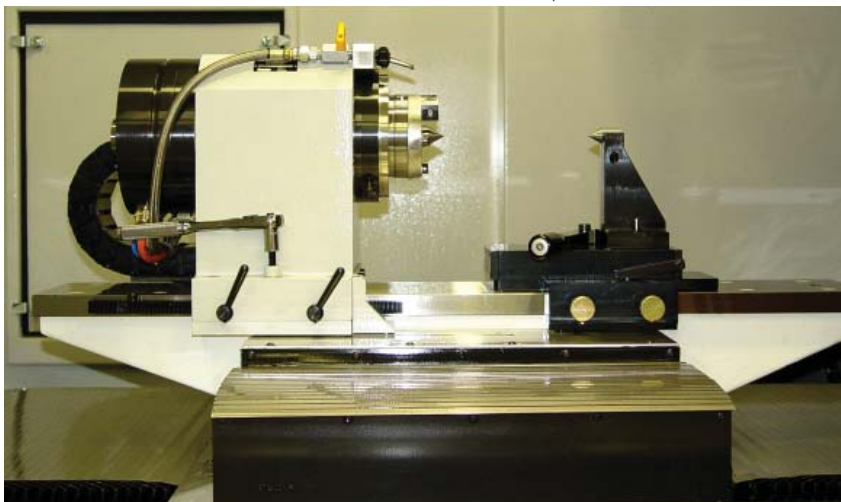

Rail mounted Headstock and Tailstock

Standard Features:

- Num Axium five axis CNC controller with digital servo motors
- Six-station grinding wheel and coolant line manifold changer
- Direct-Drive grinding spindle
- HSK wheel pack mounting
- Head stock adjustable for tools up to 21" OAL
- Air purged grinding spindle and head stock
- Stand alone closed loop chiller for grinding spindle and headstock
- Heidenhain Glass Scale on all axis
- Part Probing on grinding spindle
- Wheel Probing
- Zoned high pressure coolant delivery system
- NUMROTOplus software with standard 2D simulation
- PC interface with flat screen
- Pivoting operator console
- Ergonomic design for the operator
- Air-conditioned electrical magnetic enclosure
- Vibration dampening leveling pads
- On Board maintenance and alignment procedures
- Full disclosure of machine drawing
- 12 Month Warranty
- 24 Hour Service Response



Cutting tools manufactured on the PTG-6

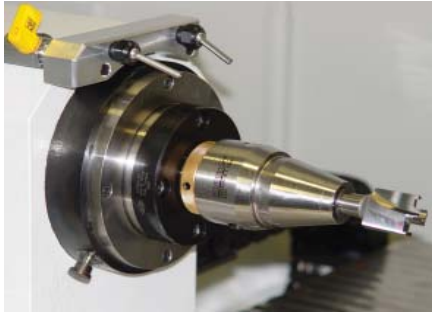

HSK Quick Change Workholding option

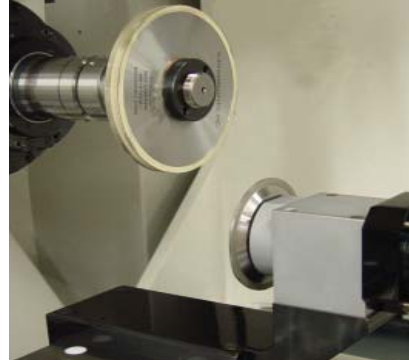

High speed truing spindle with speeds up to 12,000 rpm for truing of grit, CBN, and diamond grinding wheels.

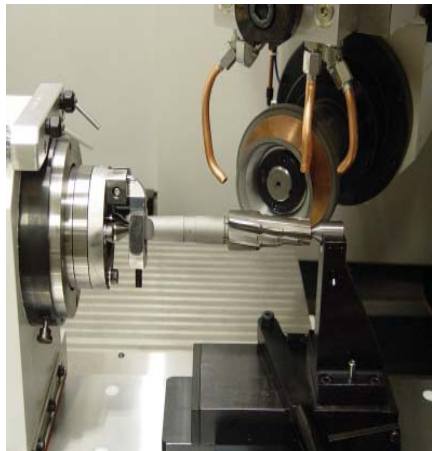

Rail mounted tailstock between centers grinding

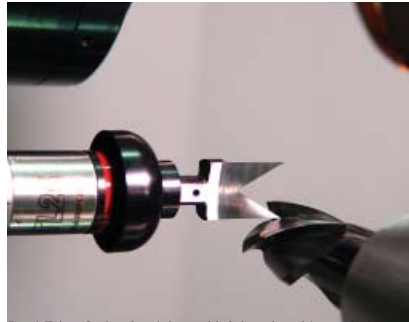

Dual Edge Stylus for right and left-hand probing capability



PTG6 with optional Pick & Place automated loader with pallet.

Optional Features:

- Coolant and Filtration Options: High Pressure system, Buster pumps, Drop-in Chiller, and Mist Collector
- On-board wheel truing
- Headstock Workholding: Nikken Bull's-eye, Schunk HSK, Schaublin and Briney
- Tailstocks: manual and programmable
- Tool Support Options: manual, programmable, gundrill clamping fixture and programmable steady rest
- Tooling Accessories: Quick Change HSK Driver and Arbor, HSK Wheel Adaptor, Dual Probe Stylus, Coolant Hole Stylus, and Shaper Cutter Stylus

NUMROTOplus® Software:

- 3D Machine Simulation & Tool Verification software
- Burrs Package
- Complex Endmills Package and Extension packages: Wave Grinder, Multiple-Helix, and Saw Cutter
- Form Cutter Package
- Step Drill Package and Extension packages: Hertel Points, Defferential Helix, Kennametal Point, K-land on Drill Points, Klenk Point, Gundrill Point, and Sharper Cutters
- Wheel Profile Determination



Tool selection screen from NUMROTOplus software

CNC Power Engineering
Hardware – Software – Brainware



Specifications

	Metric	English
Main Dimensions: Base machine (LxWxH)	2.9 x 2.3 x 2.5 m	9.41 x 7.66 x 8.41 ft
Total Weight: Base machine	5,400 kg	12,000 lbs
Maximum workpiece diameter	254 mm	10 in
Maximum workpiece length	675 mm	26.5 in
A - axis workhead spindle 360° rotation	1,000 rpm	1,000 rpm
B - axis radial travel work spindle swivel $\pm 120^\circ$	12.5 rpm	12.5 rpm
X - horizontal slide travel	300 mm	11.8 in
X - axis travel speed	15 m/min	600 i/min
Y - vertical slide travel	285 mm	11.2 in
Y - axis travel speed	15 m/min	600 i/min
Z - horizontal slide travel	500 mm	19.7 in
Z - axis travel speed	15 m/min	600 in/min
Grinding spindle speed	10,000 rpm	10,000 rpm
Spindle horsepower	46 kw	61 hp
Maximum grinding wheel diameter	150 mm	6.00 in
Smallest linear programmable movement	0.0001 mm	0.000004 in
Smallest rotary programmable movement	0.0001°	0.0001°
Rotary axis feedback resolution: A - axis	0.000068°	0.000068°
Rotary axis feedback resolution: B - axis	0.0000006°	0.0000006°

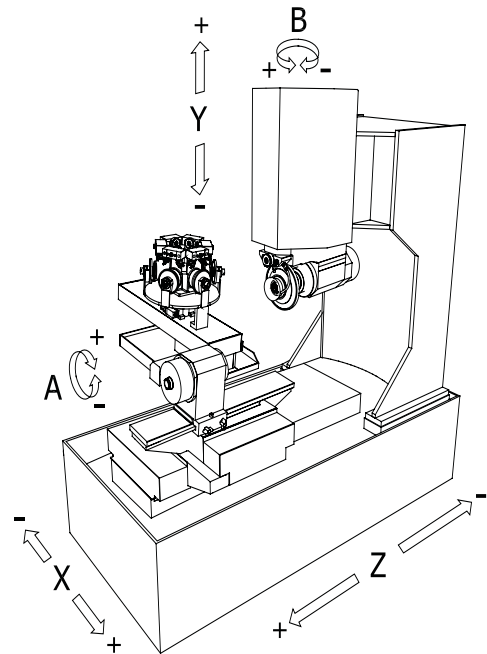
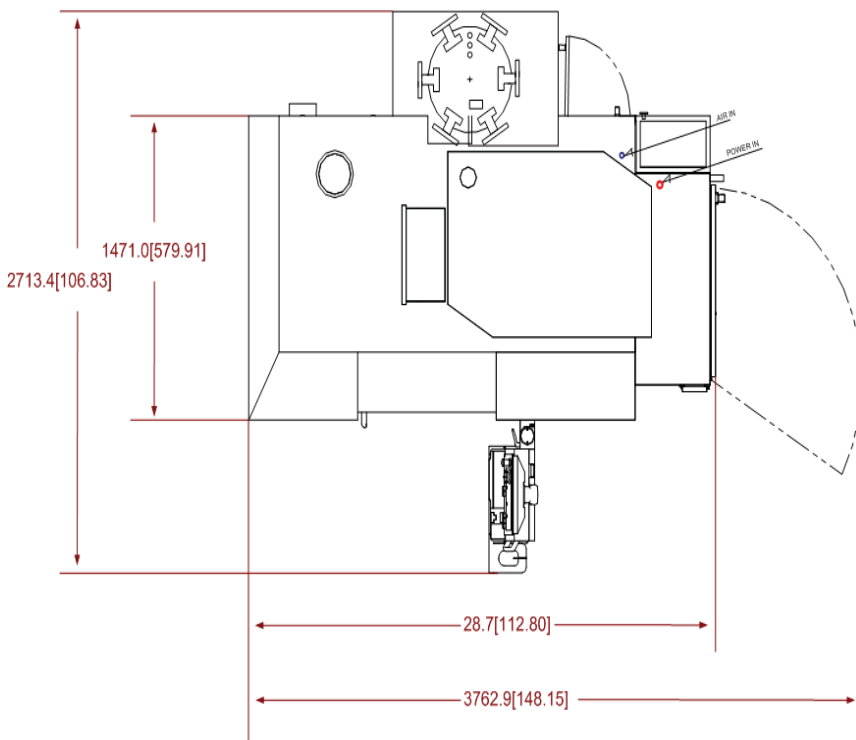

Star

System technology from one source

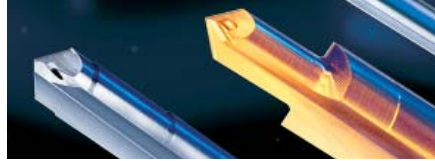

CNC Hob Sharpening Machines

CNC Shaper Cutter Sharpening Machines

CNC Broach Grinding Machines

CNC Universal Tool Grinding Machines

CNC Spline Grinding Machine

Gun Drills

Solid Carbide Drills and Reamers

Pressure Coolant Drills and Reamers

PCD Drills and Reamers

Gear Cutting Tools

Form Relieved Milling Cutters

Saw Blade Cutters

Rack Cutters

Multiple Thread Milling Cutters



Star SU LLC
5200 Prairie Stone Parkway, Suite 100
Hoffman Estates, IL 60192
Tel. 847 649 1450
Fax. 847 649 0112
e-mail: sales@star-su.com



Star SU LLC, Hoffman Estates, Illinois



Star Cutter Company, Farmington Hills, Michigan

Star SU LLC
Sales Office Michigan
23461 Industrial Park Drive
Farmington Hills, MI 48335-2855
USA
Tel. 248 474 8200
Fax. 248 474 9518
e-mail: sales@star-su.com



Star Cutter Company
Elk Rapids Engineering
Machine Tool Technology
210 Industrial Park Drive
PO Box 728
Elk Rapids, MI 49629-0728
Tel. 231 264 5661
Fax. 231 264 5663
e-mail: sales@starcutter.com



SU America Inc.
5200 Prairie Stone Parkway,
Suite 100
Hoffman Estates, IL 60192
Tel. 847 649 1450
Fax. 847 649 0112
e-mail: sales@suamerica.com



● Manufacturing
● Direct Sales
● Service Center